

REVISIONS		
REV.	DATE	DESCRIPTION

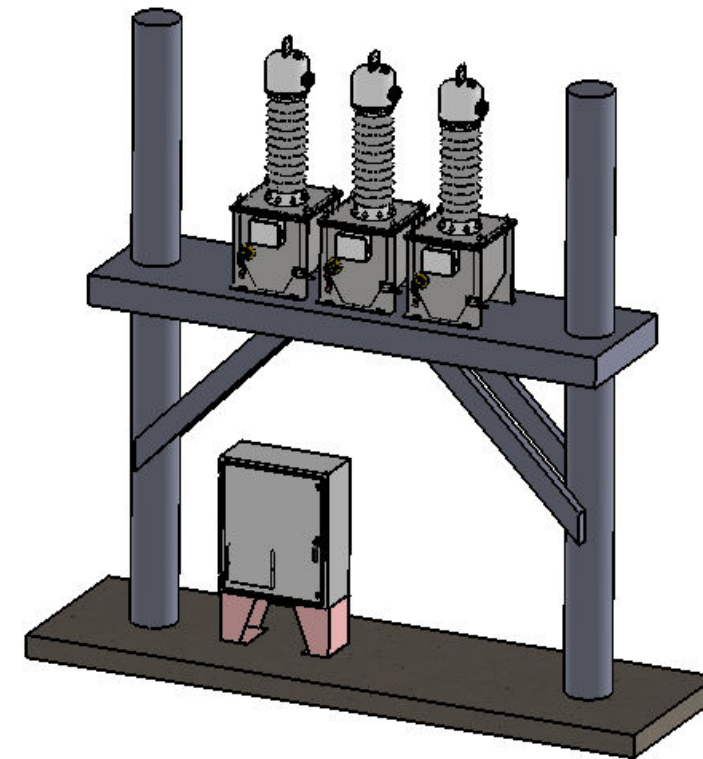
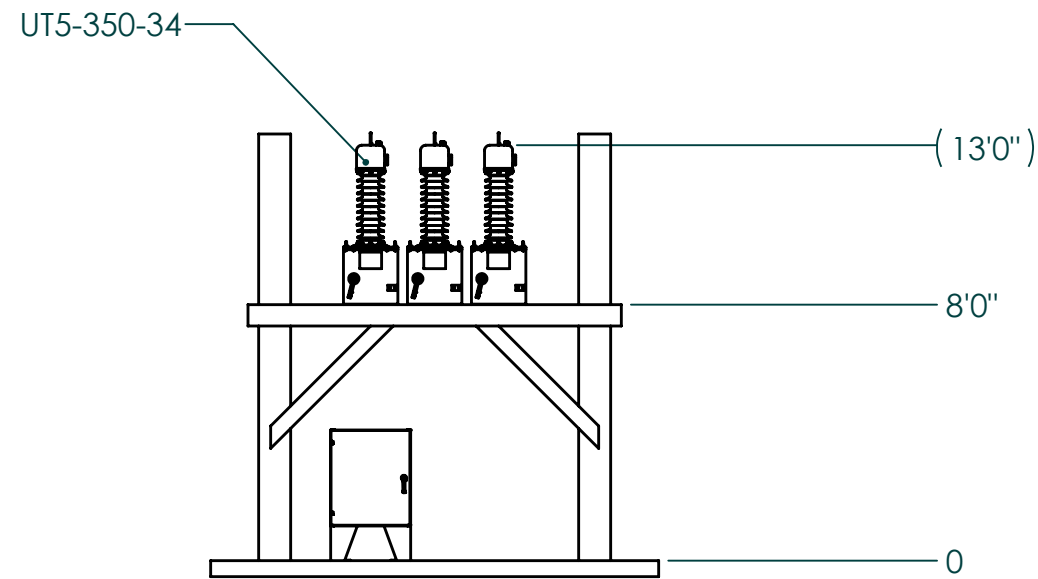
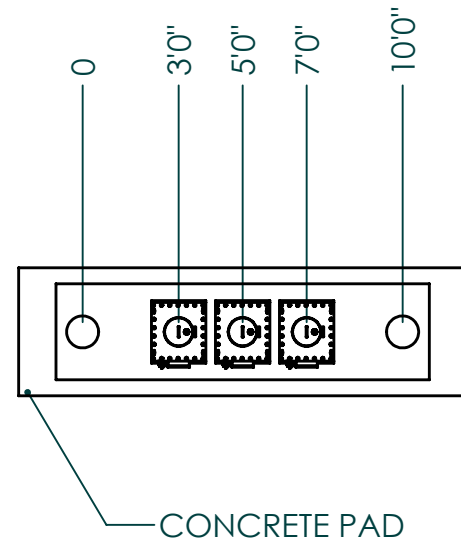

NEXT ASSEMBLY <b>TOP</b>	MATERIAL SEE BOM	DIMENSIONS ARE IN INCHES UNLESS OTHERWISE SPECIFIED	SIZE <b>B</b>	DESCRIPTION: <b>TRANSFORMER LAYOUT, 34 KV</b>	DWG. NO. <b>123-000.2.34</b>	REV <b>00</b>
WEIGHT	FINISH NONE	TOLERANCES ARE: FRACTIONS ± 1/64	DECIMALS .XX ± .01 .XXX ± .005	ANGLES ± 1/2°	MACHINED SURFACE ROUGHNESS 125 (UNLESS OTHERWISE SPECIFIED)	SCALE: 1:72 DATE: 5/7/2020
				DRAWN J Sweeney	SHEET 1 OF 1	