

Training Yard Control Panel

Bulletin 2310: Installation Manual



IMPORTANT USER INFORMATION

Read this document and the documents listed in the additional resources section about installation, configuration, and operation of this equipment before you install, configure, operate, or maintain this product. Users are required to familiarize themselves with installation and wiring instructions in addition to requirements of all applicable codes, laws, and standards.

Activities including installation, adjustments, putting into service, use, assembly, disassembly, and maintenance are required to be carried out by suitably trained personnel in accordance with applicable code of practice.

If this equipment is used in a manner not specified by the manufacturer, the protection provided by the equipment may be impaired.

In no event will Timpson Electrical & Aerial Services, LLC be responsible or liable for indirect or consequential damages resulting from the use or application of this equipment.

The examples and diagrams in this manual are included solely for illustrative purposes. Because of the many variables and requirements associated with any particular installation, Timpson Electrical & Aerial Services, LLC cannot assume responsibility or liability for actual use based on the examples and diagrams.

No patent liability is assumed by Timpson Electrical & Aerial Services, LLC with respect to use of information, circuits, equipment, or software described in this manual.

Reproduction of the contents of this manual, in whole or in part, without written permission of Timpson Electrical & Aerial Services, LLC, is prohibited.

SUMMARY OF CHANGES

This manual may contain new and updated information.
Changes throughout this manual will be listed below:

TOPIC	PAGE
Enclosure Sizes	13
Catalog Number	8
Variac Enclosure	28
High Voltage Wire Size	25
Training Unit Version 2	All
Antenna Mounting	27
Control Cable Connecting	25
Conduit Detail	17-18
Enclosure Height	9

NOTES:

Table of Contents

1. Users.....	6
a. Intended Users.....	6
b. Needs That This Unit Satisfies.....	6
2. Overview.....	7
a. General Precautions.....	7
b. Catalog Number Explanation.....	Error! Bookmark not defined.
c. Panel Dimensions and Approximate Weights.....	8
3. Installation.....	11
a. Preface & Warning.....	11
b. Environmental Ratings and Considerations.....	12
c. Site Prep.....	12
d. Mounting Pad.....	12
e. Rigging and Mounting.....	15
f. Electrical Installation.....	17
4. Warranty Statement.....	27
5. Support.....	29
a. Installation Supervision and Start-Up & Commissioning.....	29
b. New Product Satisfaction Parts Return/Repair.....	29
c. Documentation Feedback.....	29

1. Users

a. Intended Users

- This system is intended for the following users:
 - Training Yard Panel Installation Contractor
 - End-User
 - Start-Up & Commissioning Technician

b. Needs That This Unit Satisfies

- Provides the installation contractor with best practices and guidance for proper installation.

2. Overview

a. General Precautions



- i. **ATTENTION:** This Control Panel contains step-up transformers with the ability to output lethal voltages and currents. The installer should be aware and use proper lock-out-tag-out procedures when installing the electrical circuits.
- ii. **ATTENTION:** Only qualified personnel familiar with: concrete pads; rigging; and electrical construction, as well as general construction methods, should be part of the installation team of this Training Yard Panel.
- iii. **ATTENTION:** This unit contains sensitive electronics. Static control precautions are required when installing, testing, servicing, or repairing this unit.
- iv. **ATTENTION:** An incorrectly installed Training Yard Panel may result in a defective unit, voided warranty, personal injury, or death.
- v. **ATTENTION:** Risk of injury or equipment damage does exist.

b. Panel Dimensions and Approximate Weights

TYP Units with 1 to 3 Isolated Circuits

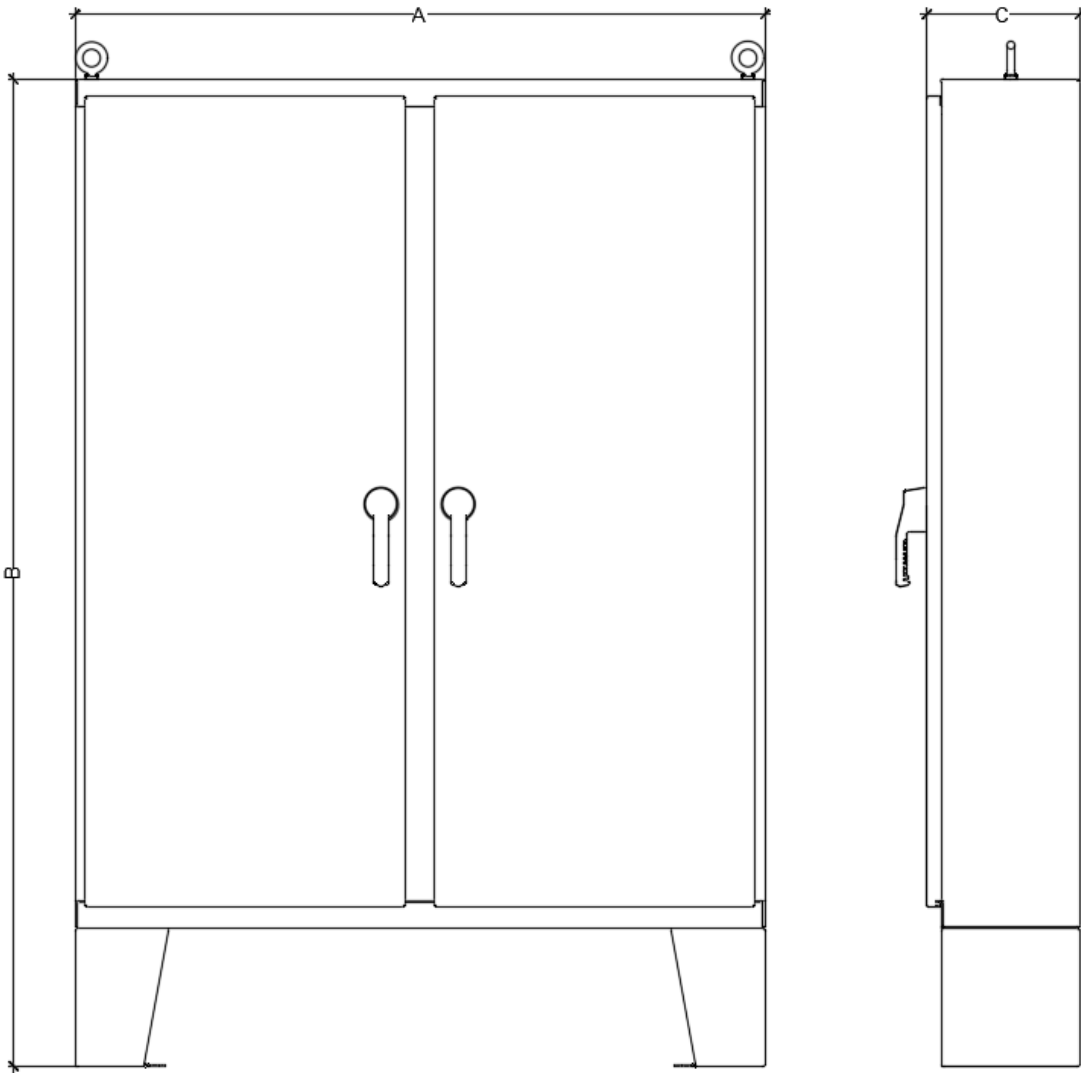

Figure - 2

Table-1

No. of Isolated Circuits	Fig.	A (in.)	B (in.)	C (in.)	Approx. Weight (lbs.)
1 to 4	2	72	84	19.3	1400

NOTES:

3. Installation

a. Preface & Warning

- i. Most start-up & commissioning difficulties and/or delays are the result of incorrect installation methods. Every precaution must be taken to assure the unit is installed within guidelines herein, and within local guidelines according to the local Authority Having Jurisdiction.
- ii. The following information is merely a guide for proper installation. Timpson Electrical & Aerial Services, LLC cannot assume responsibility for the compliance or the non-compliance to any code, national, local or otherwise for the proper installation of this unit or other equipment. A hazard of personal injury may exist if codes, guidelines, and recommendations are ignored during installation and/or use.
- iii. Debris protection: Take precautions to prevent debris from entering the enclosure during installation. Take extra care and notice when drilling electrical conduit entries, especially in the top, as metal and other debris may fall into the electronics.
- iv. Storage: Store within an ambient temperature range of -40°C to 50°C. Store within a relative humidity range of 0 to 95%, non-condensing. Do not expose to a corrosive environment/atmosphere.

b. Environmental Ratings and Considerations

- i. All Training Yard Panels are rated Nema 4 / IP 66, Weathertight, and are rated to operate outside under normal conditions.
 1. It is advised that larger units, housing 4 or more circuits, should be purchased with an enclosure A/C unit. Below are the ambient operating temperature ratings of the Timpson units:
 - a. Minimum Operating Temperature:
 - i. 0°C (32°F)
 - b. Maximum Operating Temperature
 - i. 50°C (122°F)
 2. It is advised that the end-user strongly take their local ambient weather averages into consideration before purchasing and installing the unit. High internal heat may cause nuisance tripping and may also render the unit inoperable until cooler conditions are met.

c. Site Prep

- i. Determining the location for the Training Yard Panel is important. The location shall be readily accessible to the operator of the panel. While at the panel, the location shall be such that the operator can easily view the training yard in its entirety. This will help assure that safe conditions are present before a circuit becomes energized. Failure to locate the system safely and properly may result in Timpson withholding start-up & commissioning of the system for use, until rectified. Please consult your Timpson representative for advice on installation location.
- ii. Verify that the intended location will provide the operator a level working area.

d. Mounting Pad

- i. All Training Yard Panels will need a secure and stable concrete foundation on which to be mounted. Please consult the section contained herein that lists the approximate weights of each unit.

- ii. Consult with a local professional for installation of the concrete slab for your Training Yard Panel. Timpson recommends a minimum of 24" on the sides of the unit, and 48" in front and rear of the unit for safe operator work space.
- iii. Concrete slab and area surrounding the Training Yard panel shall be bonded to the enclosure via Ground Ring and Concrete Slab bonding, using methods called out in NEC: 250.52(A)(3), 250.52(A)(4), 250.53(F), and 250.64(A).
 - 1. The ground conductor shall be terminated to a ground lug supplied at the bottom of the enclosure back pan.

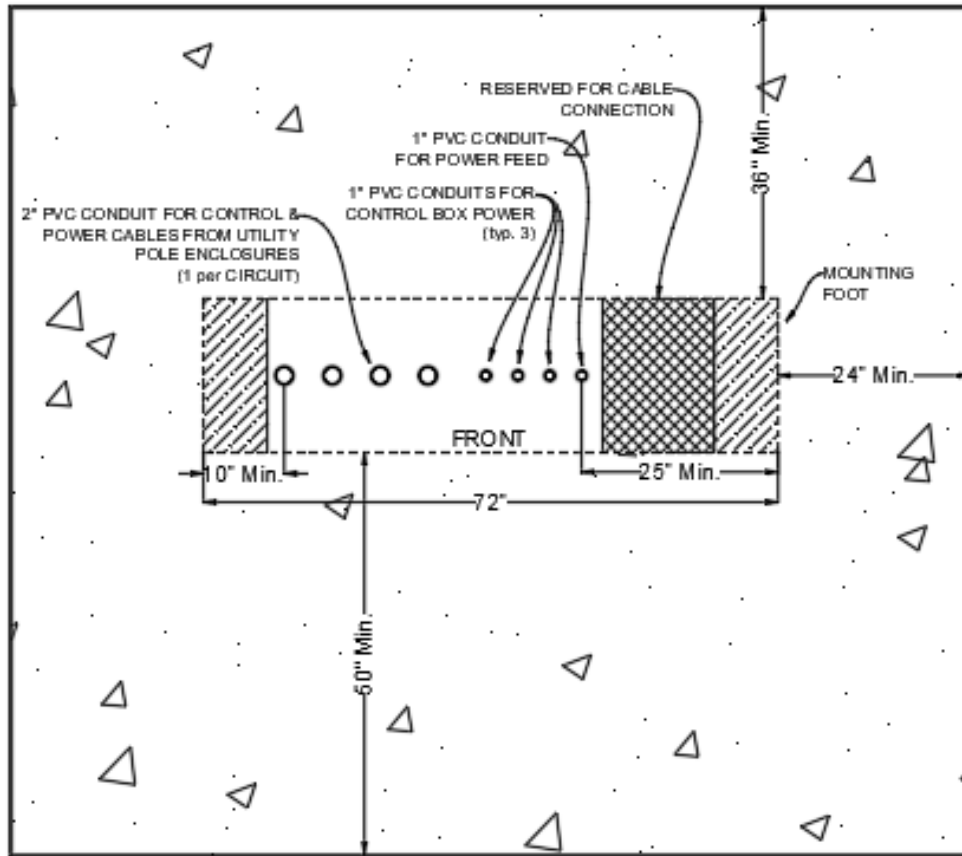

1-4 CIRCUIT PANEL

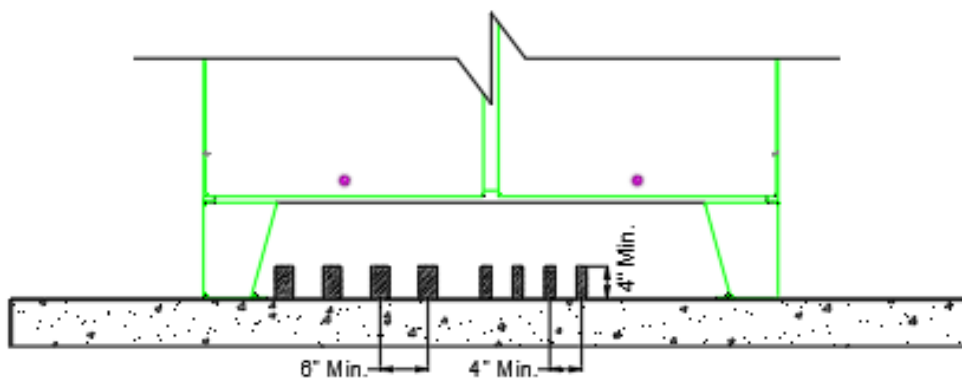

Conduit and Pad Layout for 1-4 Circuit Panel

e. Rigging and Mounting

- i. All Training Yard Panels are heavy and are considered tip-over hazards. Proper care shall be taken to assure placement be safe during and after. All panels shall be anchored to the concrete pad.
 1. Units with 1 to 3 circuits have six mounting holes in the enclosure feet. All six holes shall be anchored to the concrete pad using 1/2" drop-in type anchors or other locally approved methods. Failure to anchor the panel properly will result in tip-over, may cause injury or death, and will void any and all warranties. See Figure-5.
- ii. Rigging and placement of the unit shall be performed by those who are trained to do so. Improper rigging techniques could cause undue stress on the enclosure and any racking of the enclosure as a result may void the environmental rating, and therefore could shorten the life of the internal equipment substantially.

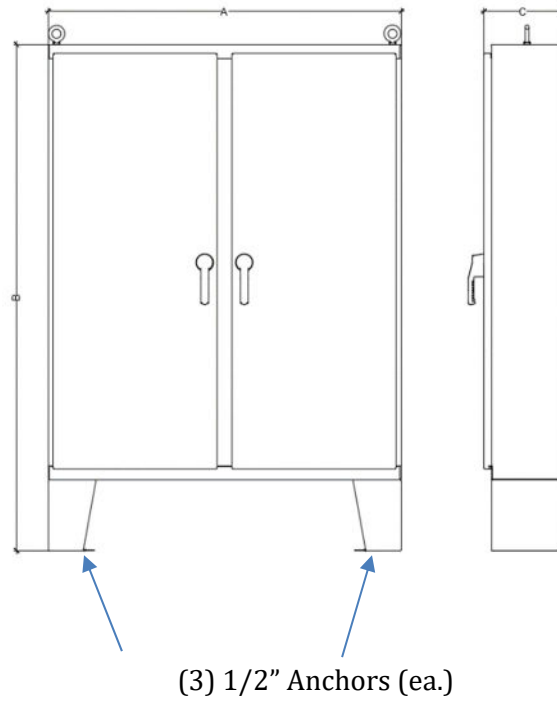

Figure - 5a

f. Electrical Installation

- i. AC Power Supply Source Considerations:
 - 1. Input Power Conditioning: This unit is suitable for direct connection to a local distribution panelboard. While Timpson recommends clean power, understanding that this is not always the case, below is a consideration for dirty power:
 - a. If your power quality meets any of the following conditions, we recommend the installation of a Line Reactor or Isolation transformer on the supply side of the unit:
 - i. Low Line Impedance;
 - ii. Line has power factor correction capacitors;
 - iii. Line has frequent power interruptions;
 - iv. Line has intermittent noise spikes;
 - 2. Input Power System: Units supplied by three-phase shall be of the Wye type. At no point, shall a center-phase-ground or high-leg type Delta system be permitted to power the Training Yard Panel.
- ii. Supply Conductor Sizing and General Grounding Requirements
 - 1. Feeders and equipment grounding conductors shall be sized according to the table Table-2 below:

Table-2

No. of Circuits	Phase	Supply	OCPD Size (Amps)	Qty.	Feeder Size	Qty.	Neutral Size	Qty.	Ground Size
1-3	3	120-208	30	3	#10awg	1	#10awg	1	#10awg

- 2. Equipment grounding conductors shall be isolated and originate at the panelboard where the supply circuit conductors originate.
- iii. Fusing and Circuit Breakers
 - 1. The Training Yard Panel is provided with a main disconnect switch with a through-door type disconnect handle. The fusible disconnect within the panel will have the same fuse rating as shown in the table above. It is the end-user's responsibility to properly install OCPD (overcurrent protection device) according to the OCPD rating in the chart above. This product shall be installed with either input fuses or an input circuit breaker located at the unit feeder origination point.
 - a. Recommended Fuse Classes:
 - i. CC, T, RK1, or J
 - b. Recommended Circuit Breakers:
 - i. Inverse Time, UL489
- iv. Terminating the Incoming Power Supply:

1. The incoming power supply feeders shall enter the unit enclosure either through the bottom of the enclosure, or through the top-right-hand-corner of the enclosure, near the main disconnect.

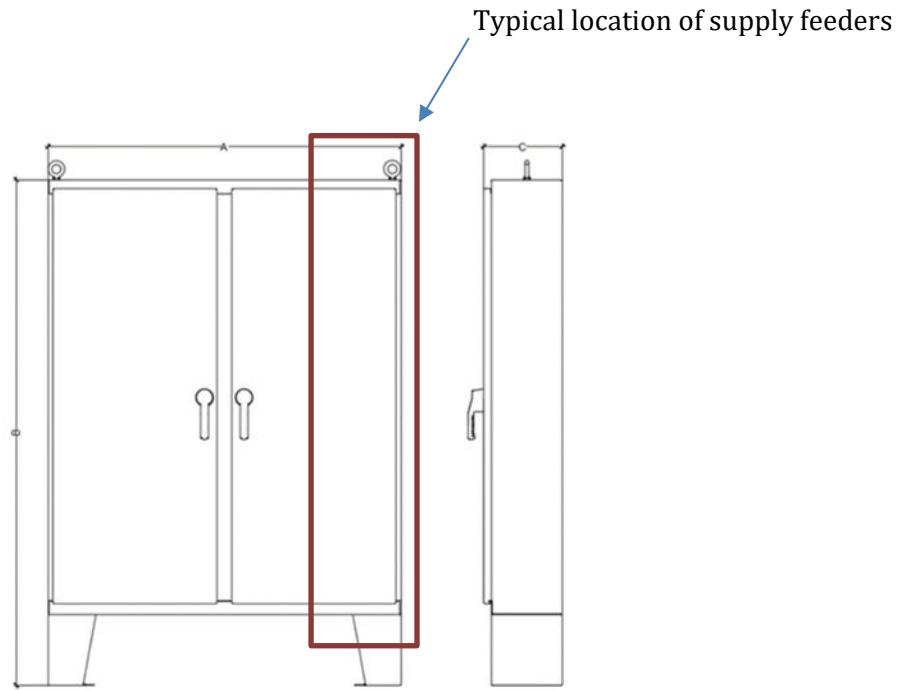
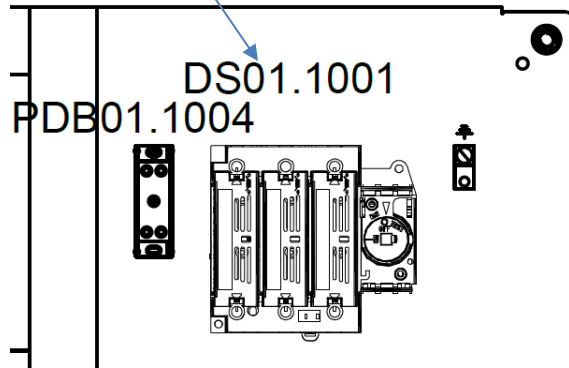

Figure - 7

Terminate main power feeders here:

Figure - 8



Note: Main Disconnect (depending on power requirements, all units will have a neutral PDB for the required neutral)

Incoming power shall terminate to L1, L2, L3 on disconnect switch DS0x.1001. Neutral conductor shall terminate to the single pole distribution block adjacent to DS0x.1001. Likely PDB0x.1004.

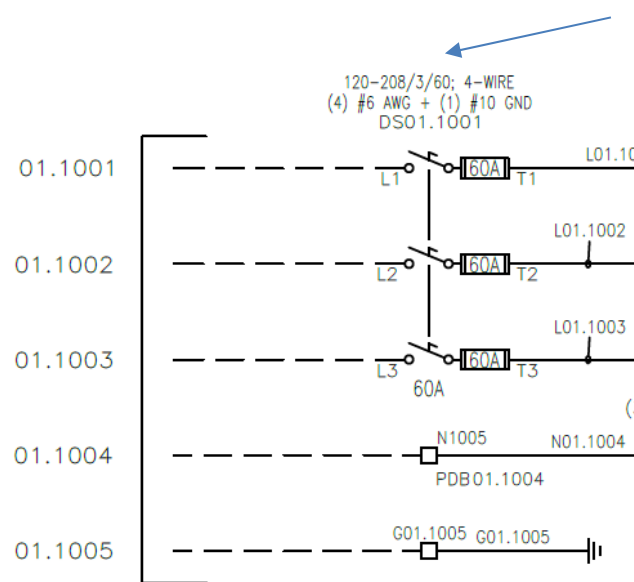

Verbiage will differ with unit. See table T-2.

Figure - 9

- 2. Supply Conductor Ratings:
 - a. Supply feeder conductors shall be rated:
 - i. THHN
 - ii. 75°C/90°C
 - iii. 600V
- 3. Supply Voltage Range:
 - a. The accepted supply voltage range is within 5% of the nameplate nominal voltage.
- v. Terminating the High-Voltage side:
 - 1. Version II of the Training Yard Panel now comes with the High Voltage system pole mounted. The High Voltage Enclosure shall be mounted to the pole using (2) 5/8" through bolts.
 - 2. (3) Phase conductors and (1) Neutral conductor terminate to the bushings provided. The Phase bushings protrude from the top of the enclosure and the Neutral bushing is at the right-side bottom.
- vi. Terminating the Control Cables**
 - 1. ***(2) Flexible Cables that come with the High Voltage Enclosure, shall run in 2" conduit from the bottom of the High Voltage Enclosure back to the main panel. They will plug into the bottom of the enclosure.***
 - 2. ***See Figure-12 for information on running the cables from the High Voltage Enclosure back to the Main Panel. The cables are run together in a 2" PVC conduit. Be sure to pull the Female ends of the cable to the Remote Pole Mounted Enclosure and terminate the Male ends of the cables to the Main Panel.***

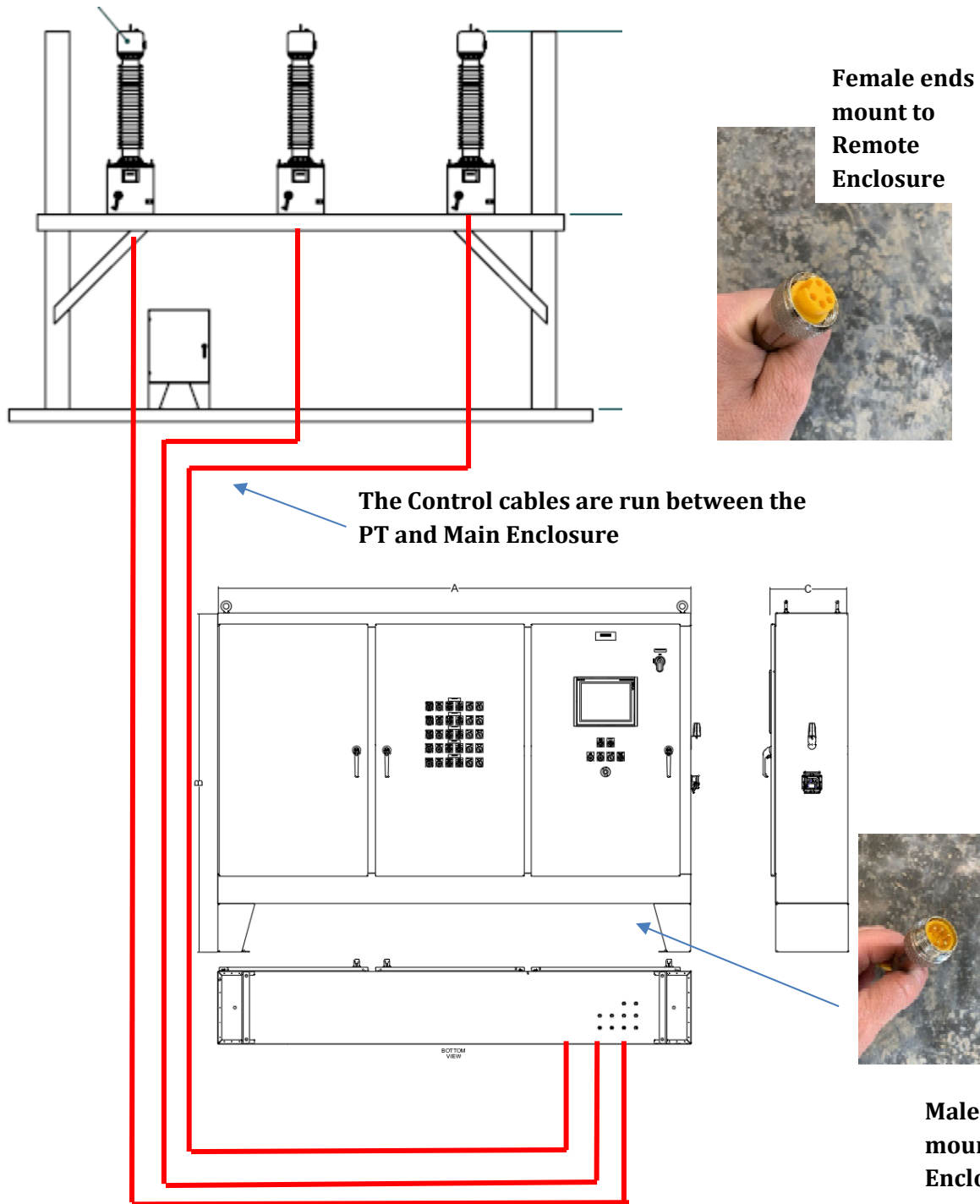

The Power cables are run in a 2" PVC conduit. One conduit to each PT

High-Voltage Conductor Ratings:

- i. *This section has been intentionally removed.*

vii. Terminating Field Devices:

1. Audible Horns and Beacons

- a. As of version II, all CKTs will have the audible horns and beacons mounted to a small enclosure, which will plug into any PT.

2. Beacons

- a. ***One Beacon will be supplied loose and is to be mounted in a general location and wired back to the panel. This is a system wide beacon that informs those who enter the training yard that at least one circuit is energized. Leave these conductors loose in the enclosure for your Timpson Start-Up Technician to terminate upon arrival. Make sure the wires are long enough to terminate at all locations within the enclosure.***

3. Remote Operator Controls



- a.
- b. If you have purchased a remote, there are some installation requirements that accompany this device. The antennas will need to be in direct line-of-sight of the remote when in use. Therefore, the antennas do not come pre-mounted to the enclosure as some customers mount the Training Yard Panel inside shed or building.



- i.
- c. Mount the antenna at or above eyesight in direct sight of where the remote will be commonly used.
- d. The antennas shall be terminated to the remote receiver box shown here:



i.

4. Remote Mounted E-Stops

- a. All units come with the ability to add remote field mounted E-Stop mushroomed pushbuttons. All E-Stops are global in the sense that any one engaged throughout the training yard will de-energize the entire yard. All remote E-stops will require redundant parallel conductors wired in series. See Bulletin 2300C for Remote E-Stop wiring information.

Figure - 15

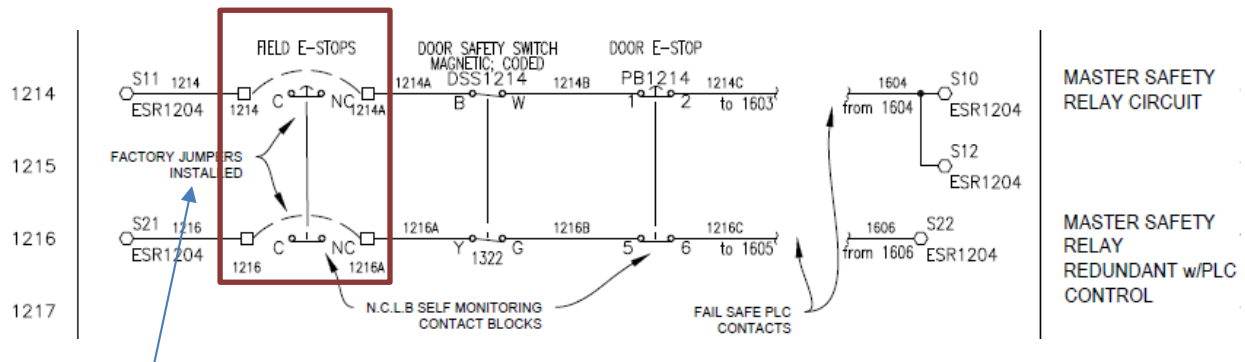

When using remote field e-stops, remove the factory jumpers and connect to the red terminal blocks.

viii. Terminating (Optional) Network Cable

1. If the Training Yard Panel is connecting to an Operator Workstation for data collection and/or monitoring, a shielded Ethernet cable shall be run from the Training Yard Panel to the location of the Workstation. The cable and installation shall meet the following criteria:
 - a. Cat5e or Cat6
 - b. Installed in a separate conduit from all power conductors
 - c. Fewer than 100m (330ft)
 - i. If linear run is greater than 100m, please contact your Timpson representative. A fiber-optic cable may be necessary in lieu of cat5e and therefore will require media converters to be supplied in the panel and in training facility.
 - d. Have ends terminated appropriately to meet 100Mbps transmission rate

Figure - 16

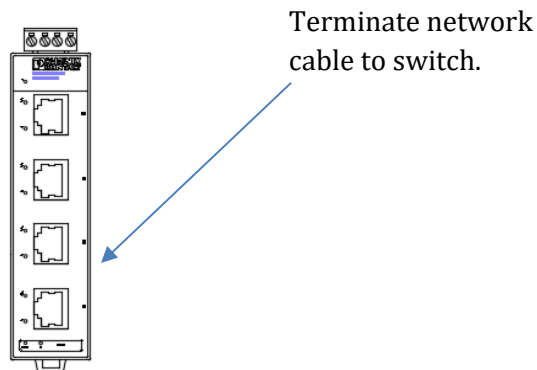

g. Variacs

i. Definition & Description

1. Each Training Yard Panel comes with one Variac adjustable transformer for each phase of each circuit within your unit. The Variacs allow the high voltage portion of the unit to be set with precision regardless of the incoming voltage range, +/- 5%.
2. As of version II, the Variacs are now mounted in the main panel.
3. Note: Transmission Variacs are servo driven and will auto-adjust voltage based on feedback plus a k-factor.

NOTES:

4. Warranty Statement

Timpson Electrical & Aerial Services, LLC. warrants the equipment manufactured by it to be free from defects in material and workmanship under normal use and service, its obligation under this warranty being limited to replacing at its factory any product, part, or parts thereof which shall, within one year after delivery of such equipment to the original purchaser, be returned, and which Timpson Electrical & Aerial Services, LLC.'s examination shall disclose to its satisfaction to have been defective. Except for the warranty hereinbefore stated TIMPSON ELECTRICAL & AERIAL SERVICES, LLC. MAKES NO WARRANTY EXPRESSED OR IMPLIED; ANY IMPLIED WARRANTY OF MERCHANTABILITY OR FITNESS FOR A PARTICULAR PURPOSE IS HEREBY DISCLAIMED BY TIMPSON ELECTRICAL & AERIAL SERVICES, LLC. AND EXCLUDED FROM ANY AGREEMENT MADE BY ACCEPTANCE OF ANY ORDER PURSUANT TO OUR QUOTATION. THERE ARE NO WARRANTIES, EXPRESSED OR IMPLIED, WHICH EXTEND BEYOND THE DESCRIPTION ON THE FACE HEREOF. Timpson Electrical & Aerial Services, LLC. neither assumes nor authorizes any person to assume for it any other liability in connection with the sale of its equipment. This warranty will not apply to any equipment which has been modified outside of its factory in any way so as, in Timpson Electrical & Aerial Services, LLC.'s judgment, to affect its stability, or reliability, nor which has been subject to misuse, negligence, or accident or to improper operation or storage, or to other than normal use or service. Timpson Electrical & Aerial Services, LLC. shall not be held liable for damages, direct or consequential, or delays, if such occurs on account of defective materials, or workmanship, or delays in shipment. Timpson Electrical & Aerial Services, LLC. will not grant any allowance for any repairs of alterations made without written consent of an officer of Timpson Electrical & Aerial Services, LLC. Timpson Electrical & Aerial Services, LLC. will in no way be liable or responsible for injuries or damages to persons or property, arising from or out of use or operation of the equipment within described. Timpson Electrical & Aerial Services, LLC. reserves the right to make changes in design or to make additions to, or improvements in, its product without imposing any obligations upon itself to install them on its products previously installed. Timpson Electrical & Aerial Services, LLC. may provide assistance in the form of recommendations, engineering or technical information and advice but such information is furnished only as an accommodation and Timpson Electrical & Aerial Services, LLC. shall have no liability for incomplete, faulty or inaccurate advice, recommendations or assistance, negligent or otherwise.

IN ADDITION: Timpson Electrical & Aerial Services, LLC.'s liability under this Warranty shall be limited to the repair or replacement of any defective work or material, F.O.B. Havre de Grace, Maryland, USA. Customer shall be responsible for notifying Timpson Electrical & Aerial Services, LLC., in writing, of any claims against this Warranty. Upon receipt of such a written claim, Timpson Electrical & Aerial Services, LLC., shall advise customer as to the warranty action to be taken. Timpson Electrical & Aerial Services, LLC. shall have the sole right to determine what action, if any, is to be taken. Any unauthorized repairs to Timpson Electrical & Aerial Services, LLC. products or systems may cause this warranty to be declared null and void.

Timpson Electrical & Aerial Services, LLC. shall not be liable for any consequential damages including lost sales and profits, injury to person or property, or any other incidental losses.

There are no warranties or remedies for the breach thereof beyond those previously described.

5. Support

Timpson Electrical & Aerial Services provides technical information within this manual, over the phone, and on-site to assist you in using its products.

At www.timpsonllc.com you can find technical assistance measures such as FAQ's and support numbers.

In addition, we offer multiple support programs for installation and continued use. For more information, contact your local representative or a Timpson Electrical & Aerial Services representative.

a. Installation Supervision and Start-Up & Commissioning

Timpson Electrical & Aerial Services offers Start-Up & Commissioning as a separate cost. All training yards are different and require a different number of days based on the number of panels, circuits, and travel requirements.

b. New Product Satisfaction Parts Return/Repair

Timpson Electrical & Aerial Services tests all of its products and systems to help ensure that they are fully operational before they were shipped from our manufacturing facilities. However, if your product is not functioning properly, please contact Timpson directly to discuss parts replacement/repair. Due to the nature of the sensitive electronics, no unit, in part or in whole, may be returned.

c. Documentation Feedback

Your comments will help us serve your documentation needs better. If you have any comments or suggestions on how to improve this document, please contact Timpson customer service.